

MAINTENANCE MANUAL

Global Series

Air Operated Double Diaphragm Pumps

G25

WARNING



- For your own safety, be sure to read these procedures carefully before performing maintenance on this product. After reading this document, be sure to keep it handy for future reference.

This maintenance manual covers what you should know about maintenance of the G25 Diaphragm Pumps. This edition is based on the standards for the July 2016 production run. Remember, the specifications are always subject to change; therefore, some of the information in this edition may not apply to new specifications.

Warnings and Cautions

For safe use of this product, be sure to note the following: In this document, warnings and cautions are indicated by symbols. These symbols are for those who will operate this product and for those who will be nearby, for safe operation and for prevention of personal injury and property damage. The following warning and caution symbols have the meanings described below. Be sure to remember their meanings.



WARNING : If you ignore the warning described and operate the product in an improper manner, there is danger of serious bodily injury or death.



CAUTION : If you ignore the caution described and operate the product in an improper manner, there is danger of personal injury or property damage.

Furthermore, to indicate the type of danger and damage, the following symbols are also used along with those mentioned above:



This symbol indicates a DON'T, and will be accompanied by an explanation on something you must not do.



This symbol indicates a DO, and will be accompanied by instructions on something you must do in a certain situation.

WARNING



- Before starting maintenance work, cut off the feed air and clean the pump. If air pressure or residue remain in the pump, there is danger of explosion, or possible poisoning resulting in serious injury or death if chemicals adhere to the skin or are accidentally swallowed. (For details on cleaning the pump, refer to Chapter 6 of the Operation Manual.)



- When replacing parts, be sure to use the recommended genuine parts or Equivalents. Use of other parts may cause a malfunction of the product. (Refer to Exploded View and Reminder to order correct item on the separate sheets.)

CAUTION



- Refer to 10.1 "Specifications" in the Operation Manual. Also, remember that the pump is heavy, and extreme care must be taken when lifting it.

Table of Contents

·Warnings and Cautions

·Table of Contents

1. Principles of operation	1
2. Tools, etc	
2.1 General tools	1
2.2 Misc.	1
3. Ordering Replacement parts	1
4. Balls and Valve seats	
4.1 Removal	2
4.2 Inspection	3
4.3 Installation	3
5. Diaphragm and Center rod	
5.1 Removal	4
5.2 Inspection	5
5.3 Installation	5
6. Spool Valve Assembly and Sleeve Assembly	
6.1 Removal	6
6.2 Inspection	6
6.3 Installation	6
7. Throat bearing and Pilot valve Assembly	
7.1 Removal	7
7.2 Inspection	8
7.3 Installation	8
8. Retightening of Tie rods	9

1. Principles of operation

There are two diaphragms fixed to the center rod, one at each end. When compressed air is supplied to air chamber b (right side, see Fig. 1.1), the center rod moves to the right, the material in material chamber B is pushed out, and at the same time material is sucked into material chamber A.

When the center rod is moved full-stroke to the right, the air switch valve is switched, compressed air is sent to air chamber a (left side, see Fig.1.2), and the center rod moves to the left. The material in material chamber A is pushed out, and at the same time material is sucked into material chamber B.

Through repetition of this operation, material is repeatedly taken in and discharged out.

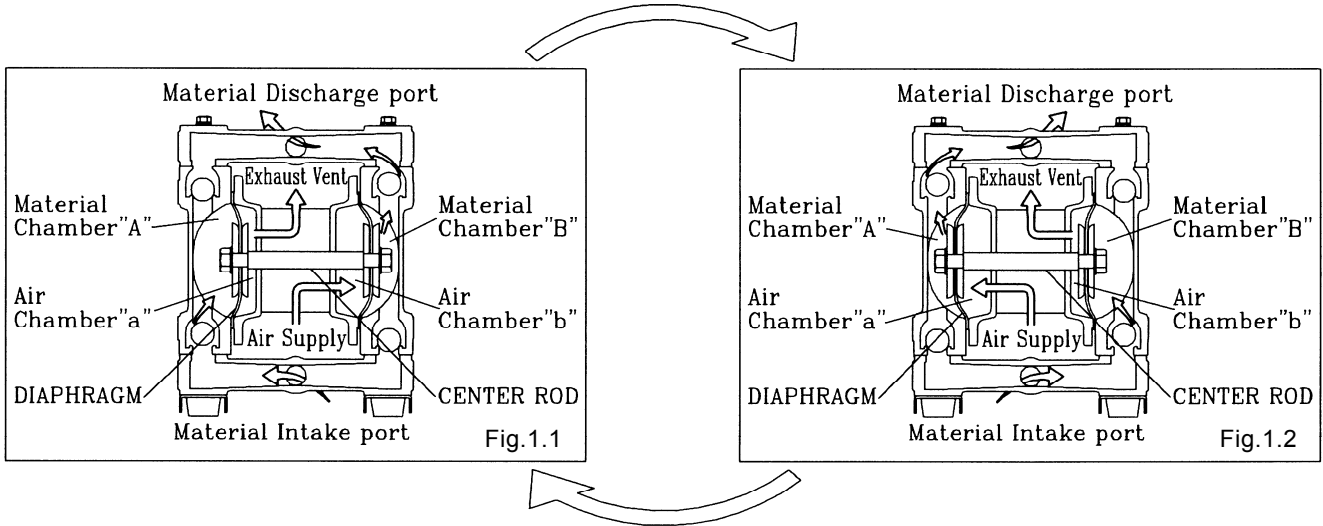

2. Tools, etc.

2.1 General tools

- Socket wrenches 10mm, 17mm, 22mm
- Snap ring pliers

2.2 Misc.

- Assembly oil Turbine oil none addition class 1(equivalent ISO VG32 grade)
- Hexagon thin nut M14×1.5
- Grease Urea grease grade (NLGI) No. 2
- Lubricants Equivalent to (LOCTITE ANTI-SEIZE 767)

3. Ordering Replacement parts

For accurate and speedy shipment of parts, be sure to order the right parts for your model to distributor. Indicate the part numbers, descriptions, and quantities.

4. Balls and Valve seats

4.1 Removal

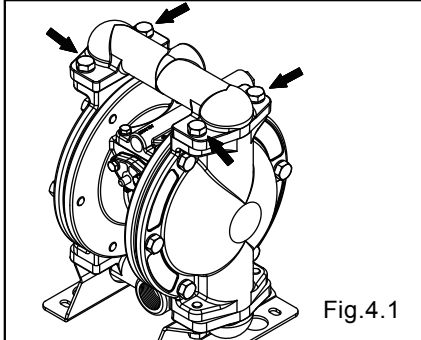

- Remove the 4 retainer bolts from the out manifold, and remove the out manifold. [Fig.4.1]

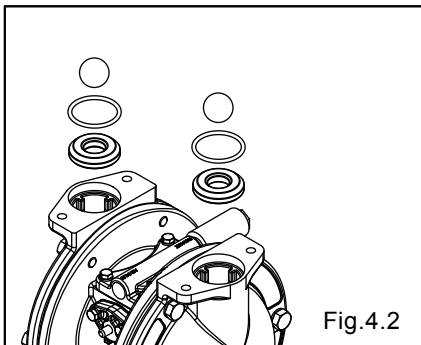

- Remove the ball, O ring, and valve seat. [Fig.4.2]

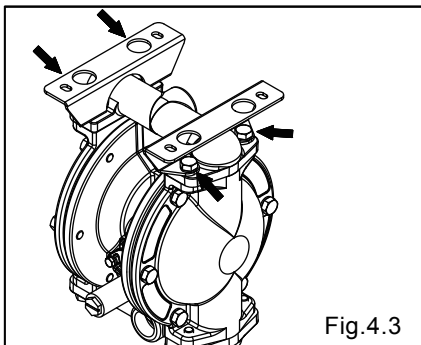

- Turn over the main body assembly. [Fig.4.3]
- Remove the 4 retainer bolts from the in manifold, and remove the in manifold and pump bases. [Fig.4.3]

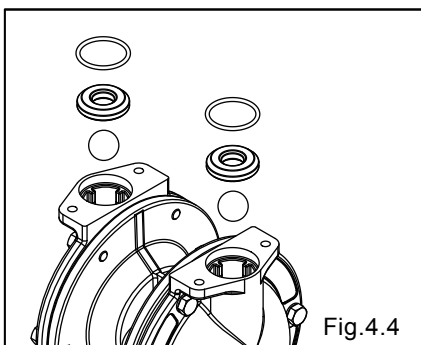

- Remove the O ring, valve seat and ball. [Fig.4.4]

4.2 Inspection

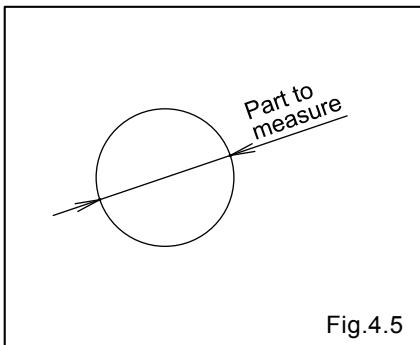

- Ball [Fig.4.5]
Measure the outside diameter, and if it is outside the usable range, replace the ball.

Usable range of Ball

$S\varnothing 0.957 \sim S\varnothing 1.095$ in { $S\varnothing 24.3 \sim S\varnothing 27.8$ mm}

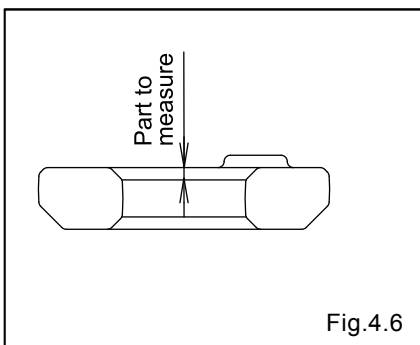

- Valve seat [Fig.4.6] [Fig.4.7]
Measure the dimension shown at left, and if it is outside the usable range, replace the valve seat.

Usable range of Valve seat

0.16in less {4 mm}

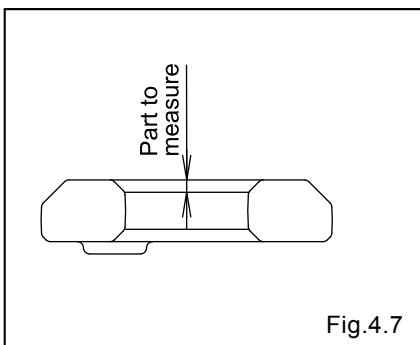

- O ring
If O ring is worn out or cracked, replace it.

4.3 Installation

For installation, see [Exploded View] on the separate sheet and install in the reverse order of disassembly.

Tightening torque for manifold retainer bolts

8 ft-lbf {10 N-m}

<NOTE>

- Make sure there is no dust on the seal surface and the seal is not damaged.

5. Diaphragm and Center rod

5.1 Removal

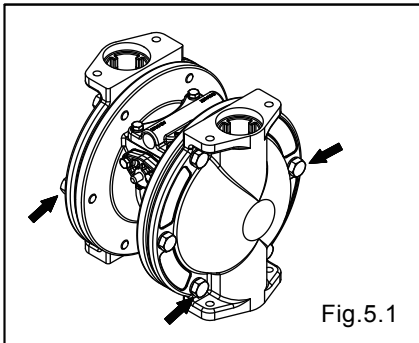

- Remove the ball and valve seat etc. (see [4.1 Removal])
- Remove the 12 retainer bolts from the out chamber, and remove the out chamber. [Fig.5.1]

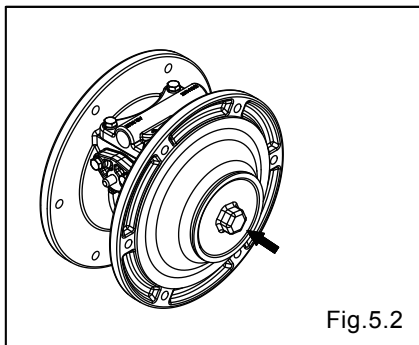

- Remove one side of the center disk(outer) [Fig.5.2]
- Remove the diaphragm, center disk(inner), washer, then remove The other side of center disk, diaphragm and the center rod. [Fig.5.2]

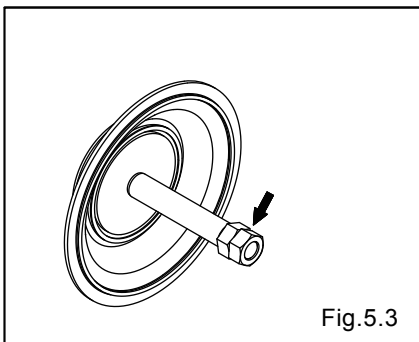

- Remove other side of the center disk(outer) from the center rod using double nuts.[Fig.5.3]
- Remove the center disk(inner), washer and the diaphragm.

5.2 Inspection

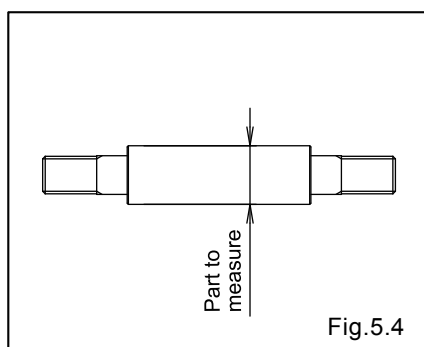

Fig.5.4

- Diaphragm
If the diaphragm is worn out or damaged, replace it.
New replace just one diaphragm.

Guideline of diaphragm life

NBR	7,000,000 cycle
-----	-----------------

- Center rod [Fig.5.4]
Measure the diameter, and if it is outside the usable range, replace the center rod.

Usable range of center rod

$\phi 0.704 \sim \phi 0.709$ in { $\phi 17.9 \sim \phi 18.0$ mm}
--

5.3 Installation

For installation, see [Exploded View] on the separate sheet and install in the reverse order of disassembly.

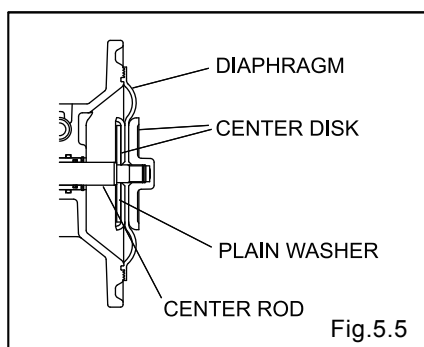

Fig.5.5

- Apply grease to the center rod, and insert it into the main body.
- Keep the “OUT SIDE” mark of the diaphragm at the liquid side.
- Draw the center disk to one side, (cf. Fig.5.5) and install the out chamber. Tighten the bolts temporarily.
- Draw the center disk to the opposite side, then turn the diaphragm over (cf. Fig.5.5). And install the out chamber. Tighten the bolts temporarily.
- After installation of the out chambers on both sides, place the pump on a flat surface and stand the pump upright for further assembly.

Tightening torque for out chamber.

8 ft-lbf {10 N-m}

<NOTE>

- Make sure there is no dust on the seal surface in order to prevent seal damaged.
- Tighten the bolts that balance should be equal from both side on diagonal line with even torque.

6. Spool Valve Assembly and Sleeve Assembly

6.1 Removal

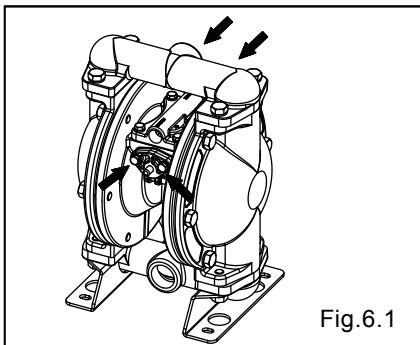

- Unscrew the four bolts and remove the plate B, the plate C and the gasket.[Fig.6.1]

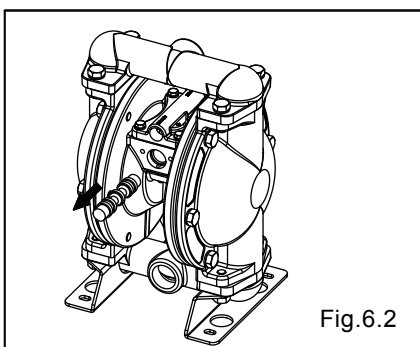

- Remove the spool valve assembly, and remove the seal rings from the spool valve assembly.[Fig.6.2]

6.2 Inspection

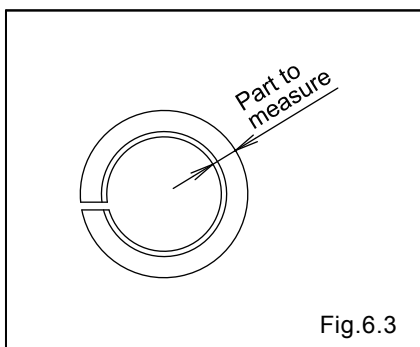

- Spool Valve Assembly
If thickness of the seal ring is outside the allowable range, replace to the new one.[Fig.6.3]
If the seal ring is worn out or damaged, replace to the new one.

Allowable range of seal ring 0.1157 ~ 0.1189 in {2.94 ~ 3.02 mm}

6.3 Installation

For installation, see [Exploded View] on the separate sheet and install in the reverse order of disassembly. The plate B is used as a tool at “7.Throat bearing and Pilot valve Assembly” it must be installed after removal, check and installation of the pilot valve assembly.

Tightening torque for installation plate A and plate B and plate C 4.5 ft-lbf {6 N-m}
--

<NOTE>

- Make sure there is no dust or damage on surface of the seal ring.

7. Throat bearing and Pilot valve Assembly

7.1 Removal

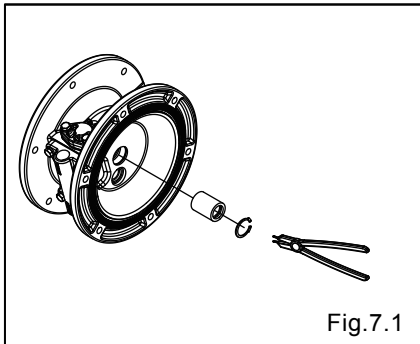

- Remove the diaphragm and center rod (see [6.1 Removal]).
- Remove the snap ring by snap ring pliers.[Fig.7.1]
- Draw out the throat bearing. [Fig.7.1]

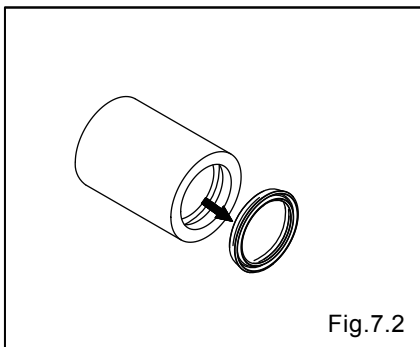

- Remove the packing from the throat bearing. [Fig.7.2]

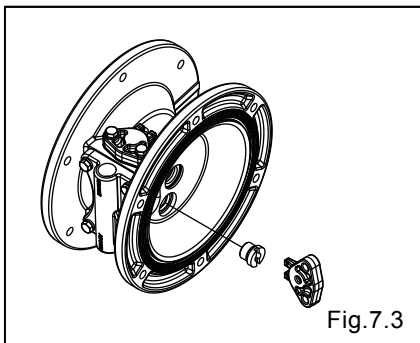

- Remove the valve seat by the plate B (refer [6.1 Removal] for the plate B). [Fig.7.3]

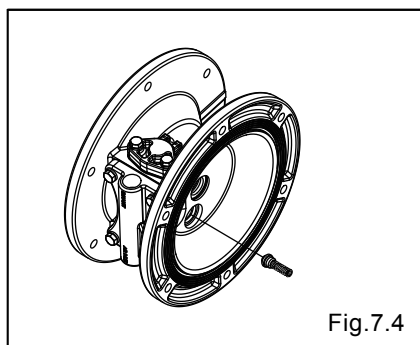

- Remove the pilot valve assembly. [Fig.7.4]

7.2 Inspection

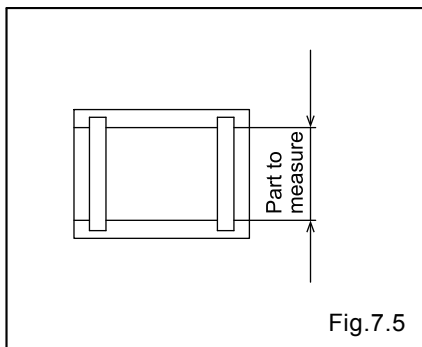

- Throat bearing [Fig.7.5]
Measure the inside diameter, and if it is outside the usable range, replace the throat bearing.

Usable range of throat bearing

$\varnothing 0.711 \sim \varnothing 0.717$ in $\{\varnothing 18.05 \sim \varnothing 18.20 \text{ mm}\}$

- O ring, Packing
If the O ring is worn out or cracked, replace it.
- Pilot valve assembly
If the pilot valve is worn out or cracked, replace it.

7.3 Installation

For installation, see [Exploded View] on the separate sheet and install in the reverse order of disassembly.

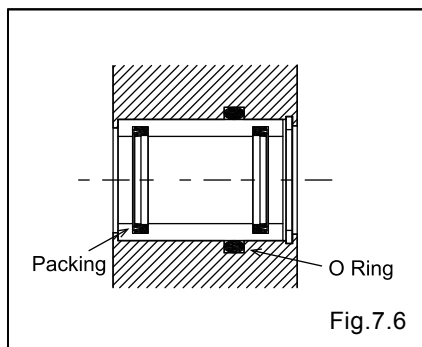

<NOTE>

- Make sure there is no dust on the seal surface and the seal is not damaged.
- Apply grease to packing.

8. Retightening of Tie rods

■ Metal type

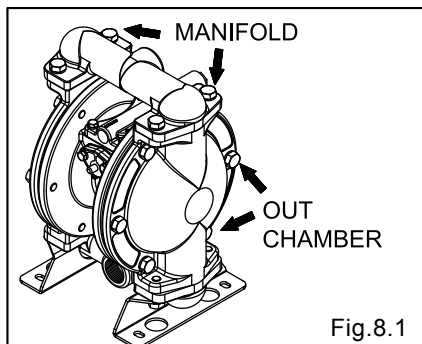

- The torque should be applied on the occasion of
(1) Right before the pump to use.
(2) There are any leaks of material on daily inspecting a pump.

	Retain bolts for the out chamber	Retain bolts for the manifold
G25	8 ft-lbf {10 N-m}	8 ft-lbf {10 N-m}

<NOTE>

- Tighten the bolts that balance should be equal from both side on diagonal line with even torque.
- Retighten the Out chamber and then the manifold in this order.
[Fig.8.1]

YAMADA AMERICA, INC

955 E. ALGONQUIN RD., ARLINGTON HEIGHTS, IL 60005, USA
PHONE : 1-855-336-5425 (Toll Free) FAX : 1-847-631-9273
www.gseriespump.com

Manufactured by:

YAMADA CORPORATION

International Department
1-1-3 CHOME, MINAMI MAGOME, OHTA-KU, TOKYO, 143-8504, JAPAN
PHONE : +81-(0)3-3777-0241 FAX : +81-(0)3-3777-0584

201607 NDP486M